



Operating Manual

Remote control

Steca PA 15



1	INTRODUCTION	4
2	SAFETY INSTRUCTIONS AND DAMAGE EXCLUSIONS	4
2.1	Symbols used for safety instructions.....	4
2.2	About this manual	5
2.3	General safety instructions	5
3	INSTALLING THE STECA PA15 TTS REMOTE SWITCH	6
3.1	Precautions.....	6
3.2	Choosing the installation site	6
3.2.1	Wall installation PA15	7
3.2.2	Mounting the remote switch	7
3.2.3	Proximity to consumer equipment	7
3.3	Preparatory measures	8
3.3.1	Line preparation	8
3.3.2	Preparing the cabling	8
3.3.3	Cabling work	8
3.4	Installation and commissioning.....	9
3.4.1	Connecting the PA15 to the DC system:	9
3.4.2	Connecting the consumer equipment.....	9
3.5	Disassembly.....	9
3.6	Safety measures	9
3.6.1	Fuse in the PA15	10
3.6.2	Flammability	10
3.6.3	Fuse protection.....	10
3.7	Earthing.....	11
3.7.1	Positive earthing	11
3.7.2	Negative earthing	12
4	THE OPERATING MODES	12
4.1	General notes on configuration:.....	12
4.2	Release for the data transfer on the SOLARIX TAROM / POWERTAROM	13
4.3	Decentralised power management (SOC MANAGER P1<P2)	14
4.3.1	What does this mean?	14
4.3.2	How to do this.....	14
4.3.3	Example	17
4.3.4	Special features, using the button / switch	17
4.3.5	Safety function / behaviour on faulty data transfer	17
4.4	Generator manager (SOC MANAGER P1 > P2)	18
4.4.1	What does this mean?	18

4.4.2	How to do this	19
4.4.3	Special features, using the button / switch	21
4.4.4	Safety function / behaviour on faulty data transfer	21
4.5	Solar manager	22
4.5.1	What does this mean?	22
4.5.2	How to do this	22
4.5.3	Special features, using the button / switch	24
4.5.4	Safety function when reception fails	24
4.6	Excess management (excess)	25
4.6.1	What does this mean?	25
4.6.2	How to do this	25
4.6.3	Special features, using the button / switch	26
4.6.4	Safety functions in the event of transmission failure	26
4.7	Nightlight (NIGHTLIGHT)	27
4.7.1	What does this mean?	27
4.7.2	How to do this	28
5	HELP WITH TROUBLESHOOTING	28
6	EXAMPLE SYSTEMS	32
7	FUNCTIONAL DESCRIPTION	32
8	TECHNICAL DATA	39
9	MISCELLANEOUS	39

Steca GmbH; Version of 04.04; No. 711.576

1 Introduction

Congratulations on your purchase!

The Steca PA15 TTS remote switch for the Solarix TAROM charge controller is a future-oriented device which can be used to realise many power management functions in a fast and uncomplicated way.

This device can be used for the following functions in your solar-powered standalone network with system voltages of 12V, 24V and 48V:

- Realise decentralised, priority-led power management,
- Integrate into your system additional solar module arrays and other add-on generators such as wind or water (relay or contactor required as the switch element),
- Activate one or more excess consumers automatically (start signal output),
- When the battery begins an exhaustive discharge, start an emergency generator to recharge your battery (start signal output),
- Or create an automatic nightlight.

2 Safety instructions and damage exclusions

Steca GmbH and its suppliers cannot accept any liability for any damage or losses arising as a result of the use of this manual.

Steca GmbH and its suppliers cannot accept any liability for any damage, losses or third party claims arising as a result of the use of the Steca PA15 TTS remote switch.

Steca GmbH and its suppliers cannot accept any liability for any damage or losses arising as a result of malfunctions, empty batteries or repair work.

2.1 Symbols used for safety instructions

Safety instructions for personal protection are marked in this manual with the  symbol and are **printed in bold**.

Notes relating to the functional safety of the system are **printed in bold**.

Safety instructions from manufacturers of additional components connected to this remote switch must be observed. This manual must not be used as a replacement for such instructions. In the event of any discrepancy between the different manuals, please contact your specialist dealer.

2.2 About this manual

This manual describes the function and assembly of a remote switch for power management in a solar-powered standalone network.

For the assembly of any other components, such as solar cells, charge controllers and consumers, and for the installation of the battery banks, please see the relevant assembly instructions from the manufacturer.

Tip: Before starting work, read the section: 3 – Please ensure, therefore, that the connected loads and performance characteristics given in the “Technical data” section are observed.

 Before carrying out any assembly work, ensure that all preparatory steps have been taken.

Only begin the assembly work when you are sure that you have understood the technical information in this manual and only carry out the work in the sequence specified in the manual!

The manual must also be accessible for third parties for all work being carried out on the system.

This manual forms part of the Steca PA15 TTS remote switch and must be included in any onward transfer of ownership.

2.3 General safety instructions

For your safety, it is essential that the following points are observed during assembly work:

Avoid any sparking in all working procedures!

Solar modules generate a current on light incidence. The full voltage is present even at low light incidence. For this reason, work carefully and observe the relevant safety precautions.

During assembly and electrical installation in the DC circuit for the photovoltaic system, double the values of the system voltages may occur (in the 12V system up to 24V, in the 24V system up to 48V and in the 48V system up to 96V).

 **Therefore: Do not touch any bare cable ends!**

Please also note that with powerful solar systems, a high-intensity arc may occur in some circumstances when an electrical connection is disconnected. This arc could cause fire, skin burns and temporary blindness. For this reason, ensure that the lines to be connected are dead when installing the device.

 **Therefore: Before disconnecting electrical connections, ensure that they are not carrying any current!**

Use only well-insulated tools!

Do not use any measuring equipment which you know to be damaged or functioning incorrectly!

The inherent safety measures in the design of the remote switch can be impaired or deactivated if the switch is operated in a way not specified by the manufacturer.

Please ensure, therefore, that the connected loads and performance characteristics given in the “Technical data” section are observed.

3 Installing the Steca PA15 TTS remote switch

3.1 Precautions

Do not install or operate any PV components in areas where flammable gas mixtures may occur!

Explosive oxyhydrogen gas may be generated in the vicinity of the battery. For this reason, ensure good ventilation around the battery and avoid sparking!



The following legal regulations for batteries must be observed:

⇒ DIN VDE 0510 Part 2, Sections:

- 7. Precautions against the risk of explosion
- 8. Precautions against dangers from electrolytes (sulphuric acid)
- 9. Positioning

⇒ National Electric Code including Article 690

3.2 Choosing the installation site

The Steca PA15 must be connected to the battery and the consumer devices. As the line losses and therefore also the voltage drops need to be kept as low as possible, the PA15 must be installed in such a way that the cable paths selected are as short and direct as possible. The line lengths to the consumer equipment can only be affected in a minimal way as on-site distribution is required.

The PA15 must not be installed in areas where there are flammable liquids or gases. Installation is only permissible in an area with sufficient protection classification for the PA15 (see Technical data). The minimum and maximum permissible ambient temperatures must always be observed at the installation site. In addition, the PA15 must not be installed or operated in humid conditions (e.g. bathrooms), or in rooms where flammable gas mixtures may occur, e.g. from gas cylinders, paint, varnish, solvents, etc.

The remote switch must be protected against the direct effects of the weather. Direct sunlight and heating from neighbouring devices must be avoided.



Batteries and the PA15 must be installed in a position inaccessible to children and unauthorised persons. No arrangements should therefore be made to provide access to the PA15 by unauthorised persons.

 **The base on which the PA15 is installed must not consist of flammable material. During operation, the device will heat up due to power dissipation. For this reason, the installation site should withstand a temperature of 85°C.**

3.2.1 Wall installation PA15

The PA15 must be installed on an incombustible base. In addition, there must be no flammable materials underneath the installation site.

The remote switch can in principle be installed horizontally or vertically. The PA15 is screwed onto the wall using the bores in the housing. The remote switch is designed without strain relief so that the conductor cross-section can be modified in accordance with the site conditions. For this reason, during installation a strain relief device (e.g. cable clips) should be fitted approx. 200mm underneath the device before the cable strands are distributed onto the individual components.

The wiring work can be started once the PA15 has been mechanically installed.

3.2.2 Mounting the remote switch

The device can be used as a template in order to mark out the mounting holes

 **Only use the PA15 as a marking template, and never as a template for drilling**

3.2.3 Proximity to consumer equipment

The PA15 contains a highly sensitive data receiver whose function may be impaired by radio interference. For this reason, do not install the device in the immediate proximity of consumer equipment. Maintain a minimum spacing of 1.5m.

Data reception may be disrupted, especially when used in the immediate vicinity of consumer equipment containing a DC/DC converter, equipment containing a radio transmitter or other devices which emit electromagnetic signals.

The PA15 must not be installed in the immediate vicinity of the following device types in particular:

- Energy-saving lamps
- Television sets
- DC/DC converters (e.g. MPP tracker, voltage converter for consumer equipment)
- DC/AC converters (inverters)
- Telecoms systems, mobile telephones, radio equipment

The equipment listed above can be connected to the PA15, of course, but the spatial distance must be observed in order to prevent interference with the data reception.

3.3 Preparatory measures

3.3.1 Line preparation

All lines, distributor cans and boxes and fuses should normally be prepared before connection:

- Cut to length
- Strip on both sides and crimp on the wire end ferrules as necessary
- Prepare the distributor cans

3.3.2 Preparing the cabling



Cables not permanently connected to the housing must be fitted with strain relief outside the device.

Ensure that the cable cross-section conforms to the maximum load current. Use cables with a minimum cross-section of 2.5mm² for the maximum permissible load current of 15A.

3.3.3 Cabling work

Please read the instructions on connecting the PA15 in section 3.4 *Installation and commissioning* before starting the cabling work.

The PA15 is connected directly to the battery for the solar system.

A short-circuit in the battery must be avoided at all costs. This could result in the PA15 and the battery being destroyed.

Please therefore ensure that the rechargeable batteries are disconnected from the system before installing the PA15.

And only reconnect the battery once it has been ensured that the cabling is functioning correctly.

When assembling onto an existing solar system, please note that solar modules will generate a current even at low light incidence.

Please ensure that the system is not carrying any voltage from the solar modules after the system battery has been disconnected.

Even at low light incidence, the full voltage will be present, which may result in damage to the system. Fit the solar modules with an opaque cover securely fixed using adhesive tape. The modules can be rendered free of voltage via this cover.

- The solar modules must never be disconnected by a short-circuit. Sparking!
- Use only well-insulated tools!
- Do not touch any bare cable ends!
- Immediately insulate any bare cable end which is not connected straight away!

- Only perform work with a dry base! Components (solar modules, cables, etc.) must not be wet or damp during installation!
- Ensure that the correct polarity is used during cabling work!

Notes:

In standalone systems, earthing of the components is not necessary, not standard or may be prohibited by local regulations (e.g. DIN 57100 Part 410 Prohibition of Earthing for Safety Extra-Low Voltage Electrical Circuits).

3.4 Installation and commissioning

It is essential that all general safety instructions (section 2.3; page 5) are observed.

It is also critical that the connection sequence given in the sections below is followed. This is the only way to ensure that the commissioning process is completed correctly.

3.4.1 Connecting the PA15 to the DC system:

- Disconnect the entire system from the supply
- For additional protection for the PA15, fit a 15A fuse on the supply line to the battery
- Remove the fuse on the PA15
- Ensure that the polarity is correct on connection
- Connect the plus pole on the power lead to terminal A+.
- Connect the minus pole on the power lead to terminal A-.

⇒ Insert the fuse into the PA15.

When the device has been correctly connected to the supply lead, a short beep will be emitted to indicate that the device is being supplied with power.

3.4.2 Connecting the consumer equipment

- Each consumer circuit should be protected by an additional fuse.
- Before connecting the consumer line, switch off all the consumer equipment to prevent sparking.
- Connect the consumer line to the screw terminals on the remote switch. Ensure that the polarity is correct!
- Connect the plus pole on the consumer line to terminal L+.
- Connect the minus pole on the consumer line to terminal L-.

Lastly, secure all cables with strain relief devices in the immediate vicinity of the PA15. Strain relief devices should also be fitted to the remaining components.

3.5 Disassembly

Disassembly is carried out in the reverse order to the installation process described above. First shut down all consumer devices manually and then disconnect from the remote switch. The fuse in the PA15 can now be removed.

3.6 Safety measures

All safety measures used to protect the PA15 still may not prevent problems caused by incorrect installation external to the remote switch.

We therefore strongly recommend installing a fuse directly at the battery pole to prevent short-circuits.

3.6.1 Fuse in the PA15

The fuse is used solely to protect the PA15 against incorrect polarity and excess current. The fuse must be replaced following a polarity reversal. Only spare fuses of the same type may be used. This greatly increases the safety of the system which also means that no dangerous operating conditions occur even if the electronics fail.

3.6.2 Flammability

The PA15 comprises only non-flammable or self-extinguishing materials. Even in unforeseeable error situations, no fires can be triggered if there are no flammable materials in the immediate vicinity of the controller and the remote switch has been installed on an incombustible base.

3.6.3 Fuse protection

A fuse protects the PA15 against single faults (e.g. load short-circuit, battery reverse polarity, reverse polarity of the consumer equipment, etc.).

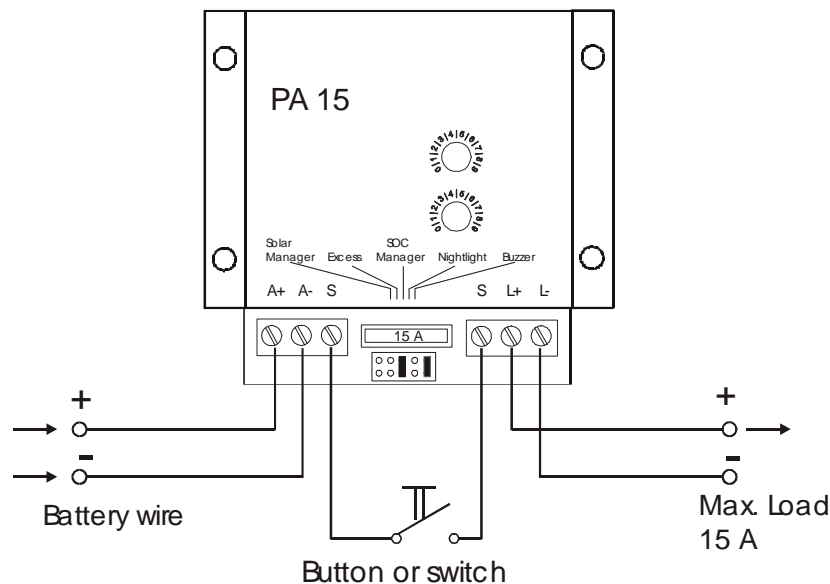

However, some double faults can result in the destruction of the remote switch and the components connected to it (consumer equipment).

The PA15 TTS remote switch can be destroyed if, for example:

- The battery has been connected with the reverse polarity on the load output,
- Regardless of the polarity, a battery connection lead is connected to the battery input (A+ or A-) and the other battery lead is connected to the load output (L+ or L-),
- The battery connection has been connected to the switch inputs S,

- The battery connections are touching the jumper board (contacts for the selecting the battery type),
- An incorrect source (e.g. network at 230V) has been connected to any connection.

3.7 Earthing

The sections below describe only the technical options for earthing. The aim is to maintain the switching functions. The local regulations where the device is being used must be observed and followed by the installation engineer. The losses in safety extra-low voltage status caused by earthing must be compensated by the corresponding insulation measures on active parts (protection against direct contact).

3.7.1 Positive earthing

If earthing on the positive side is selected, this can also be used as the common earthing for all system components. All plus lines will still be interconnected inside the device.

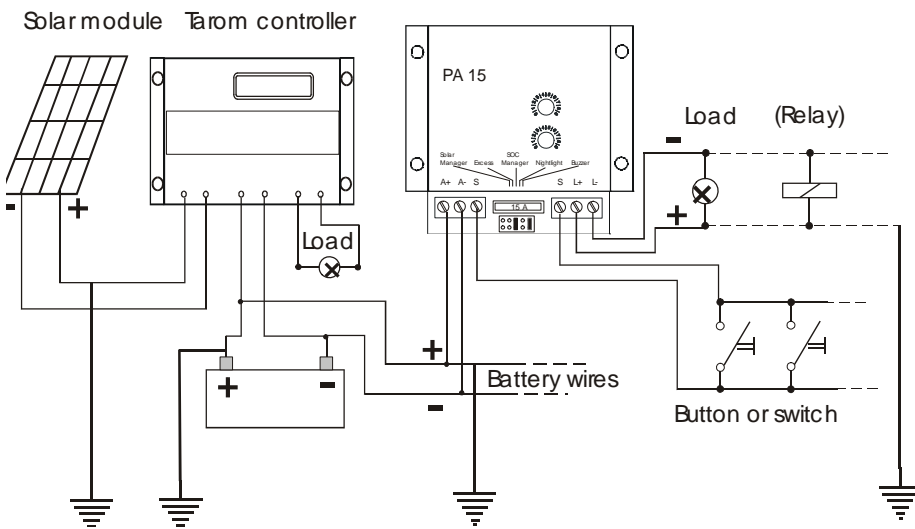

3.7.2 Negative earthing

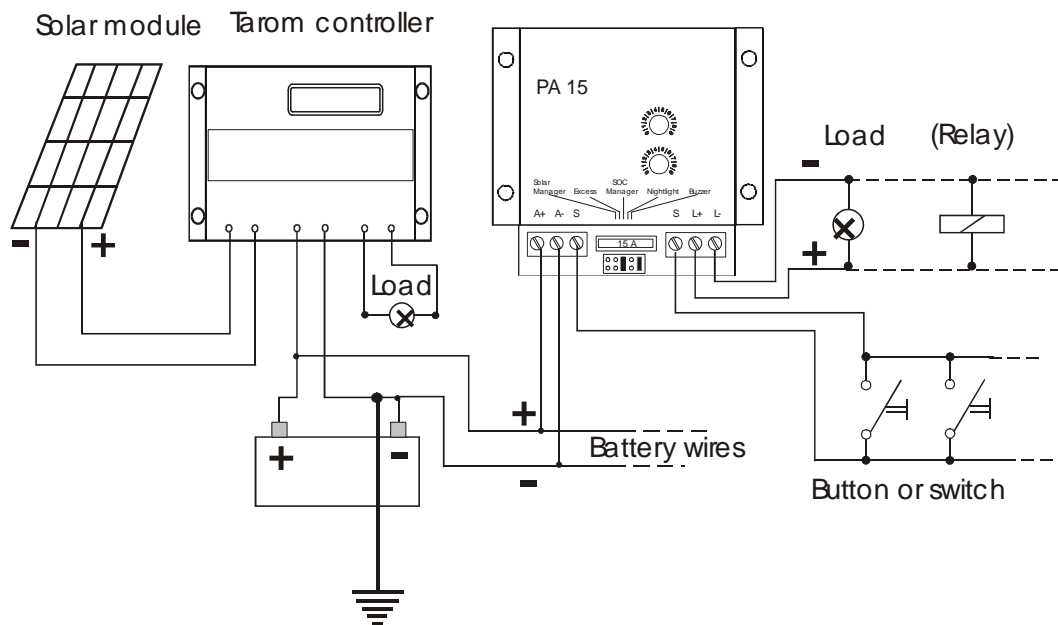

Only one connection may be earthed on each of the minus connections on the battery input and load output components.
The earthing conditions on the existing solar system must be noted.

If there is already a minus-side earthing in your solar system, only one component (in this example the battery minus) may be connected to this earth. Connecting other minus connections (e.g. L-) will bridge the switching elements inside the device and will prevent the entire device from functioning.

4 The operating modes

The remote switch has various operating modes. It can be custom-configured depending on the function required. The sections below describe how to do this.

4.1 General notes on configuration:

In order to configure the device for the required operating mode, adjusting controllers P1 and P2 need to be set and one or more jumpers need to be set correctly.

The PA15 detects most configuration errors and indicates these with an uninterrupted beep. The device indicates an error of this type if both the adjusting controllers are set to the same value or the jumpers are set incorrectly.

A button (momentary contact) or switch (permanent contact) can be connected to the PA15 between the two terminals marked with an S.

When the load output on the remote switch is triggered, the consumer equipment connected can be switched on and off using the button, just as with a remote-control switch. When the load output on the PA15 is blocked, the load output is only triggered for as long as the button is depressed. If an option for manual override is required for the PA15, a switch (permanent contact) can be connected to these terminals.

4.2 Release for the data transfer on the SOLARIX TAROM / POWERTAROM

The Steca PA15 TTS remote switch can only be operated in combination with SOLARIX TAROM 235, TAROM 245, TAROM 430 or POWERTAROM solar charge controllers, software version 12.15 and higher.

On delivery, the data transfer function is deactivated on TAROM / POWERTAROM solar charge controllers. To be able to use the PA15, the transfer function first needs to be enabled.

The PA15 does not need to be installed for this purpose.

Proceed as follows:

- Commission the TAROM / POWERTAROM charge controller in accordance with the instructions in the relevant installation manual.
- Press any key to access the first menu level.
- Then press the two outermost buttons on the TAROM/ POWERTAROM simultaneously; this will take you to the "OPTION TRANSMIT" menu.
- Press the OK button in the "OPTION TRANSMIT" menu to view the current setting.
- Use the UP / DOWN buttons to select the "AKKU" (BATTERY) mode and confirm by pressing the OK button.
- The setting will now be saved, even when the Tarom / Powertarom is not operational.
- This function can only be enabled by selecting "AKKU" (BATTERY); no data will be sent to the receiver in the "PC" and "OFF" positions.
- The "PC" option is used for servicing purposes by the manufacturer only and cannot be used.

Once the data transfer function has been enabled using the "AKKU" option, the Tarom / Powertarom start transferring one data packet to the battery lead about once a minute.

The Tarom / Powertarom transfers the following system information:

- Current SOC VALUE,
- Identifier for the generator manager
- Identifier for the excess manager (EXCESS)
- DAY / Night information

In accordance with this setting, the PA15 TTS remote switch will only react to the signals sent if it receives the information transferred at least 3 times without error.

This transfer protection features, realised using multiple reception, may result in delays in the switch response. The shortest delay time is around 4 minutes.

If the information itself changes within the required triple information transfer (e.g. the SOC changes from 60% to 59%), a third transfer of the new value will be required.

If the PA15 is unable to receive any correct signals, permanently specified safety functions become active in order to protect the system (e.g. load shut-off).

During data transfer, the power consumption of the TAROM / POWER TAROM charge controller increases for a short time. For this reason, this mode should be deactivated if not being used.

4.3 Decentralised power management (SOC MANAGER P1<P2)

4.3.1 What does this mean?

Decentralised power management can be used to assign different priorities to the consumer equipment in your standalone network, and enable or block them automatically regardless of the SOC. One or more external buttons can be connected to the device to be able to switch your consumer device on and off more easily.

You can also choose whether or not you want an acoustic early warning before the consumer device connected is shut down.

The SOC information is transferred to the battery lead by the Solarix Tarom charge controller via up-modulated signals, see section 4.2.

4.3.2 How to do this

1. Connect the PA15 to your battery lead with the correct polarity (A+ / A-).
2. Connect the consumer device to the output on the PA15 (L+ 7/ L-) with the correct polarity.

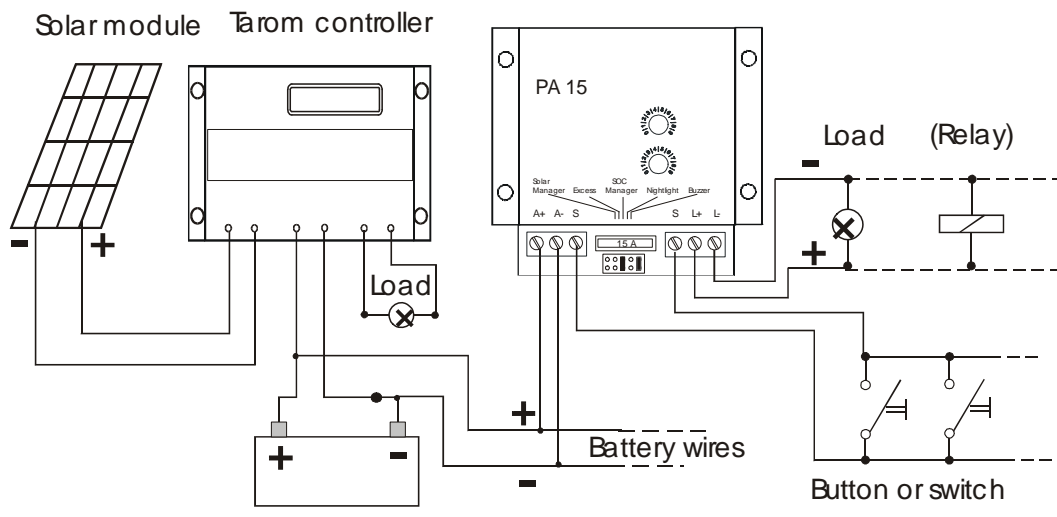

- To configure the remote switch for this operating mode, plug the jumper on the PA15 into the "SOC MANAGER" position. If you want a warning tone to be issued when the shut-down threshold is reached, also plug in the "BUZZER" bridge. The buzzer will then output a warning signal 10 times before the load is shut off, over a total period of around 1 minute.

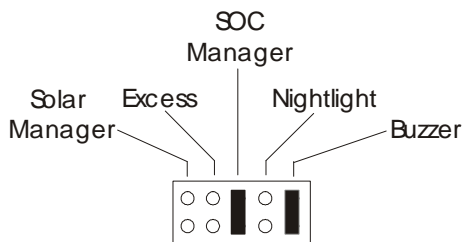

- Then set the shut-down threshold on "P1". The shut-down threshold is the SOC value at which the remote switch shuts off the connected load. Position "2" would mean, for example, that the load is shut off when the SOC \leq 29%.

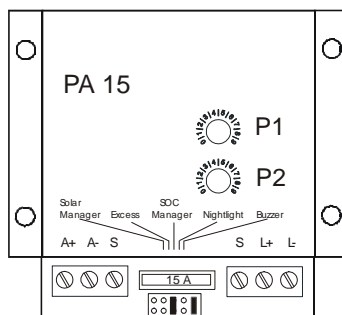
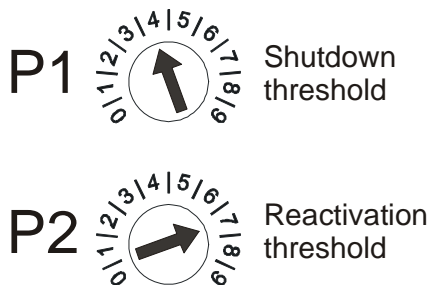

The beeps sounded when resetting the adjusting controller are normal and are intended to help you set the required values more easily.

The beep signals the transition between two setting options, e.g. starting from the far left 0, turn 4 beeps to the right = 4. SOC values between <10% and >99 % can be set on the scale from 0 – 9.

0 : SOC between 0 ... 9% (<10 %)

beep

1 : SOC between 10 ... 19% (<20 %)

beep

....

beep

8 : SOC between 80 ... 89% (<90 %)

beep

9 : SOC between 90 ... 99% (<100 %)

5. The activation threshold (hysteresis) is the SOC value at which the consumer device is to be reactivated. This value can be set on “P2”. Position “3” would mean, for example, that the load is switched back on when the SOC \leq 30%.

The beep signals the transition between two setting options, e.g. starting from the far left 0, turn 4 beeps to the right = 4. SOC values between <10% and >99 % can be set on the scale from 0 – 9.

0 : SOC between 0 ... 9% (\geq 10 %)

beep

1 : SOC between 10 ... 19% (\geq 20 %)

beep

....

beep

8 : SOC between 80 ... 89% (\geq 80 %)

beep

9 : SOC between 90 ... 99% (\geq 90 %)

6. **Please note that for this operating mode to function correctly, the value at “P1” must always be less than the value at “P2”!**

SOC manager function only when: P1 < P2

If this condition is not fulfilled, the Generator Manager function is automatically active, which has the opposite function, see section 4.4

The load output is always enabled if either the SOC value is greater than the shutdown value, or, following shutdown, the SOC is once again greater than the activation value (P2).

When making the electrical connections, please always observe section 3. In standalone systems, earthing of the components is not necessary, not standard or may be prohibited by local regulations (e.g.

4.3.3 Example

Let's say you want to connect a television set to the standalone network via this decentralised exhaustive discharge protection. It should only be possible to operate the device if the load status for the solar battery is at least 50%. Therefore, set the range "<50%" (=4) on P1. So that the television set is not switched on and off continually when the SOC fluctuates slightly, a value at least 10% higher than the shutdown threshold should be set for the reactivation threshold (P2). In other words, set "P2" to $\geq 70\%$ (=7) for example. So that the remote switch "knows" that it should act as an exhaustive discharge protection device, also set the jumper to the "SOC MANAGER" position, and if you want an acoustic early warning to be emitted, set the second jumper to the "BUZZER" position.

4.3.4 Special features, using the button / switch

If required, an external button can be connected between the two terminals marked with an S. Assuming the shutdown threshold on P1 has not yet been reached, this button can be used to switch the load break switch on the PA15 on and off manually just like a remote-control switch. Multiple buttons can also be connected in parallel in order to install multiple light switches in a room, for example. This button can also be installed at a later stage once the device is already in operation.

4.3.5 Safety function / behaviour on faulty data transfer

When the device is commissioned, the consumer output will always be enabled if the SOC is above the shutdown value (P1). In this case, it doesn't matter if the SOC is also higher than the hysteresis value (P2).

If the shutdown value (P1) has not been reached, however, the hysteresis value (P2) must be exceeded once again in order for the load to be switched on.

If the PA15 has shut off the load due to its controller position and the data transferred, the load CANNOT be reactivated by reducing the shutdown thresholds. The activation value needs to be reached first. Reactivation can only be achieved by reducing the activation value accordingly. In this case, ensure that the shutdown value P1 is always smaller than the activation value P2; if necessary, reduce the shutdown value in parallel with the activation value P2.

If the data transfer is interrupted or not activated in the Tarom, the output remains or becomes enabled, thus ensuring the operational safety of the consumer device.

If the data transfer is interrupted, the button / switch can be used to switch the consumer on or off manually.

The buzzer does not indicate an interruption in the data transfer.

In the shutdown early warning phase, all the changes in the settings are ignored, i.e. the acoustic return message is also deactivated when the controller is adjusted. If the jumper for the buzzer is removed during the warning phase, it will NOT be deactivated either!

The warning for invalid settings remains active at all times.

4.4 Generator manager (SOC MANAGER P1 > P2)

4.4.1 What does this mean?

In this operating mode, the PA15 can supply a start signal for an emergency generating set, depending on the load status of the battery. If the SOC falls below a certain value, the generator will be started via the load output on the PA15 TTS remote switch to recharge the battery.

With this function, the PA15 provides a continuous switching signal to its output for as long as the condition set is fulfilled. The amplitude of this signal corresponds to the system voltage and relates to the battery plus potential.

Before using this operating mode, it is essential to ensure that the switching signal supplied by the PA15 is suitable for the generator to be started!

Depending on the requirements, it may be necessary to modify the switch signal via additional components, e.g. relays.

These components do not form part of the Steca PA15 TTS remote switch and must be purchased and installed as an extra.

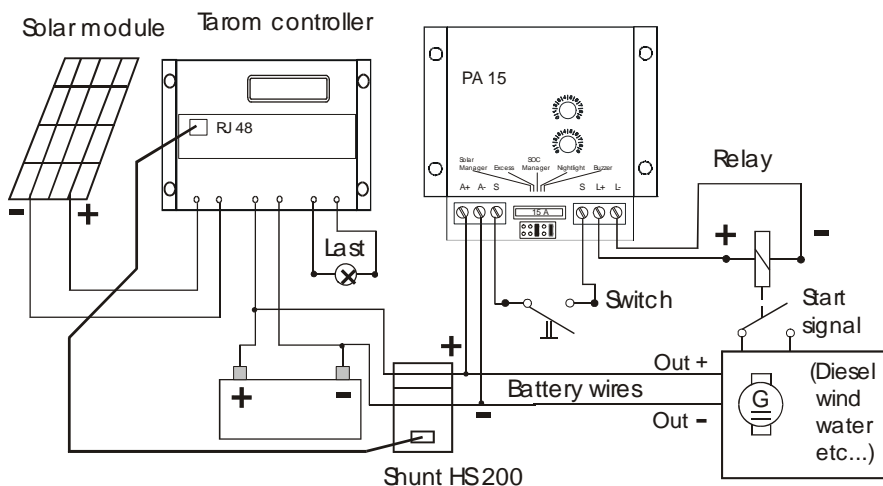

As the control is carried out according to the state of charge SOC, the actual battery voltage may in fact exceed the permissible final charge voltage before the shutdown value is reached; it must be ensured that the final charge voltage on the generator being controlled cannot reach any high, non-permissible values. For control by the PA15, only generators which have an inherent limit to the final charge voltage are suitable.

4.4.2 How to do this

This operating mode functions in almost exactly the same way as the decentralised exhaustive discharge protection described in section 4.3. The difference is that the adjusting controller is set to precisely the opposite function.

1. Connect the PA15 to your battery leads with the correct polarity (A+ / A-).
2. Connect the load output (L+ / L-) to the start input for the generator, if this is possible directly. Otherwise, a suitable signal converter is required (e.g. relay).
3. To configure the remote switch for this operating mode, plug the jumper into "SOC MANAGER".

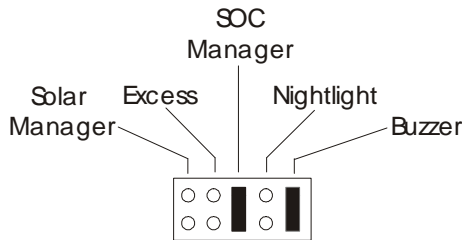

4. The position of the "Buzzer" jumper is not relevant in this operating mode. No acoustic early warnings are issued when the PA15 is switched on or off.
5. Now set the shut-down threshold on "P1". The shut-down threshold is the SOC value at which the PA15 output is to shut off the generator connected. To do this, the PA15 disconnects the connection to the battery at its output. If the current SOC value transferred is higher than the threshold set using P1, the PA15 output is disabled.

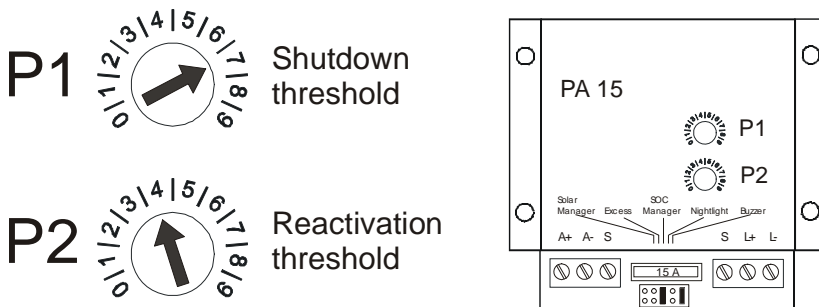

The beep signals the transition between two setting options, e.g. starting from the far left 0, turn 4 beeps to the right = 4. SOC values between <10% and >90 % can be set on the scale from 0 – 9.

0 : SOC between 0 ... 9% ($\geq 10\%$ --> OFF; $<10\%$ --> ON)

beep

1 : SOC between 10 ... 19% ($\geq 20\%$ --> OFF; $<20\%$ --> ON)

beep

....

beep

8 : SOC between 80 ... 89% ($\geq 80\%$ --> OFF; $<80\%$ --> ON)

beep

9 : SOC between 90 ... 99% ($\geq 90\%$ --> OFF; $<90\%$ --> ON)

The adjusting controller P2 must be set to a smaller value than P1 for this operating mode.

6. Now set the activation threshold on “P2”. The activation threshold is the SOC value at which the PA15 output is to start the generator. At e.g. the value “4”, the generator will be started, if the SOC is below 40%.

If this value is reached, the PA15 will connect its load output to the battery until the shut-down threshold (of P1) is reached.

The beep signals the transition between two setting options, e.g. starting from the far left 0, turn 4 beeps to the right = 4. SOC values between <10% and >90 % can be set on the scale from 0 – 9.

0 : SOC between 0 .. 9% ($<10\%$)

beep

1 : SOC between 10 .. 19% ($<20\%$)

beep

...

beep

8 : SOC between 80 .. 89% ($<90\%$)

beep

9 : SOC between 90 .. 99% ($<100\%$)

7. **Please note that for this operating mode to function correctly, the value at “P1” must always be greater than the value at “P2”!**

Generator manager function only when : P1 > P2
--

If this condition is not fulfilled, the SOC MANAGER function is automatically active, which has the opposite function, see section 4.4

When making the electrical connections, please always observe section 3. In standalone systems, earthing of the components is not necessary, not standard or may be prohibited by local regulations (e.g. DIN 57100 Part 410 Prohibition of Earthing for Safety Extra-Low Voltage Electrical Circuits).

4.4.3 Special features, using the button / switch

An external switch can also be used here between the S terminals to switch the PA15 load output on and off manually. If a switch (permanent contact) is used for this purpose, the generator can be switched on and off regardless of the status of the PA15.

Some emergency generating sets which have a start signal input may require a potential-free switching signal. As the output on the TTS is not potential-free, a relay is required for the electrical isolation in this case. Even if the starter current on the generator exceeds the maximum permissible 15A switching capacity of the TTS, a relay or contactor should be used.

 **Before connecting the TTS to your generator, ensure that the instructions for using the generator are observed.**

For the Tarom charge controller to be able to record the additional generator current and to include this in its SOC calculation, an “HS 200” type intelligent shunt should also be used, as described in the diagram above.

4.4.4 Safety function / behaviour on faulty data transfer

When commissioning the device, the consumer output is always shut down first (generator off).

Only once a relevant data signal is available to the PA 15 following a successful data transfer is the load activated.

If the PA15 has shut off the load (generator) due to its controller position P1 and the data transferred, the load can be reactivated by reducing the shutdown thresholds.

If the data transfer is interrupted or not activated in the Tarom, the output remains or becomes shutdown, thus protecting the generator against overload.

If the data transfer is interrupted, a switch can be used to switch the output (generator) on or off manually.

The buzzer does not indicate an interruption in the data transfer.

4.5 Solar manager

4.5.1 What does this mean?

Using one or more PA15 in this operating mode, your solar generator can be expanded virtually without limit in a modular way. The TAROM charge controller sends the identifiers required by the PA15 to switch solar arrays on and off depending on the final charge voltage.

Other power generators (wind, water) can also be used to charge your system battery using remote switches in the solar manager operating mode.

4.5.2 How to do this

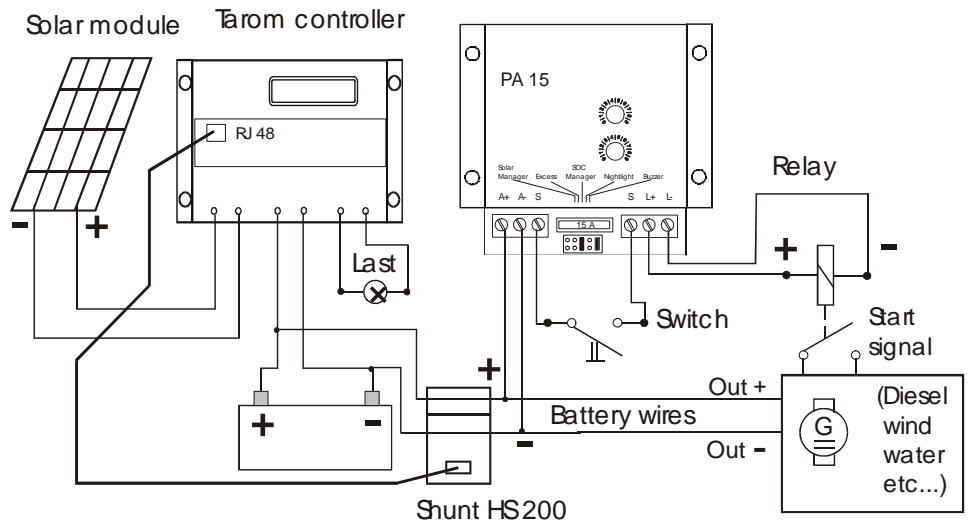

The TAROM regularly sends certain identifiers to the PA15 TTS remote switches connected, which tell the remote switches which solar arrays should work with the battery, and which should not. The module arrays are shut down in sequence when the battery voltage approaches the final charge voltage.

To be able to shut down an additional generator using the TTS, another DC relay is required with a magnet coil connected to the load output on the remote switch. For technical reasons, the PA15 cannot shut down any generator on its own

1. Connect the PA15 to your battery leads with the correct polarity (A+ / A-).
2. Connect the DC relay to the load output on the TTS. The relay must be laid out for the system voltage for the solar system and the maximum module current. The array can then be connected to the accumulator battery via this relay and an additional, intelligent shunt.

- To configure the PA15 for this operating mode, plug in the “SOLAR MANAGER” jumper.

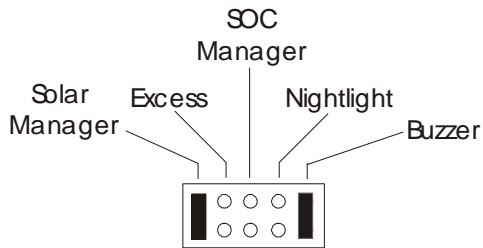

- Set the identifier (or ID number) to adjusting controller “P2”. The setting on “P1” is also ignored in this operating mode. Settings from 0..8 are accepted. The setting 9 is possible, but has exactly the same functionality as position 8. This means that a maximum of 9 additional solar arrays can be included in the system.

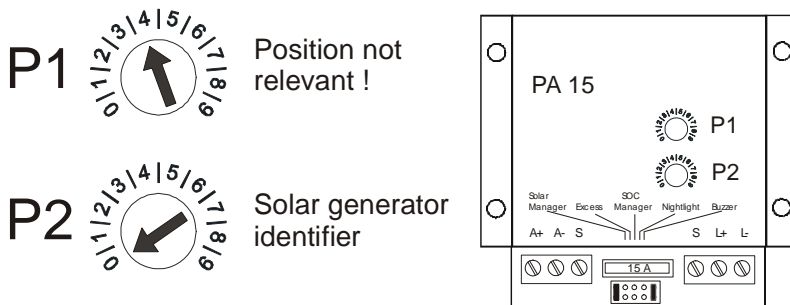

The additional generator with the allocation “8” has the highest priority and is activated first and deactivated last.

“0” has the lowest priority.

The identifiers or ID values are created depending on the current battery voltage and the final charge voltage.

The closer the current battery voltage comes to the final charge voltage, the higher the identifier transferred and the more additional generators are shut down!

Battery empty → Battery full										
P2	Identifier									
0	1	2	3	4	5	6	7	8	9	
0	ON	OFF	OFF	OFF	OFF	OFF	OFF	OFF	OFF	OFF
1	ON	ON	OFF	OFF	OFF	OFF	OFF	OFF	OFF	OFF
2	ON	ON	ON	OFF	OFF	OFF	OFF	OFF	OFF	OFF
3	ON	ON	ON	ON	OFF	OFF	OFF	OFF	OFF	OFF
4	ON	ON	ON	ON	ON	OFF	OFF	OFF	OFF	OFF
5	ON	ON	ON	ON	ON	ON	OFF	OFF	OFF	OFF
6	ON	ON	ON	ON	ON	ON	ON	OFF	OFF	OFF
7	ON	ON	ON	ON	ON	ON	ON	ON	OFF	OFF
8	ON	ON	ON	ON	ON	ON	ON	ON	ON	OFF
9	ON	ON	ON	ON	ON	ON	ON	ON	ON	OFF

If you want to include 3 additional solar arrays in your system, you need 3 x Steca PA15 TTS remote switches, 3 DC relays (contactors) and 1..3 x “HS200” type intelligent shunts. Then enter the numbers 8, 7 and 62 into the TTS connected.

4.5.3 Special features, using the button / switch

If required, an external button can be connected between the two terminals marked with an S. When the generator is active, this button can be used to switch the PA15 output on and off manually just as with a remote-control switch.

A switch (permanent contact) can be used to switch generators on and off using the PA15 regardless of the control.

The load break switch on the remote control is not able to disconnect solar modules from the battery lead. This means that external power switches such as relays or contactors are essential.

For the Tarom charge controller to be able to record the additional solar current and to include this in its SOC calculation, an “HS 200” type intelligent shunt should also be used, as described in the diagram above.

4.5.4 Safety function when reception fails

When commissioning the device, the PA15 output is always shut down first (generator off).

Only once a relevant data signal is available to the PA 15 following a successful data transfer is the output active.

If the PA15 has shut off the generator due to its controller position P2 and the data transferred, the generator can be reactivated by increasing the generator identifier.

If the data transfer is interrupted or not activated in the Tarom, the output remains or becomes shutdown, thus protecting the generator against overload.

If the data transfer is interrupted, a switch can be used to switch the output (generator) on or off manually.
The buzzer does not indicate an interruption in the data transfer.

4.6 Excess management (excess)

4.6.1 What does this mean?

If there is an excess of solar power available and the battery is already fully charged, the power generated can be used by an excess consumer device (e.g. water pump). The TAROM switches on the excess consumer via the PA15 when the battery is fully charged, before the solar current in the battery is shut off.

4.6.2 How to do this

1. Connect the PA15 to your battery leads with the correct polarity (A+ / A-).
2. Connect the consumer device to the outputs (L+ / L-) with the correct polarity.

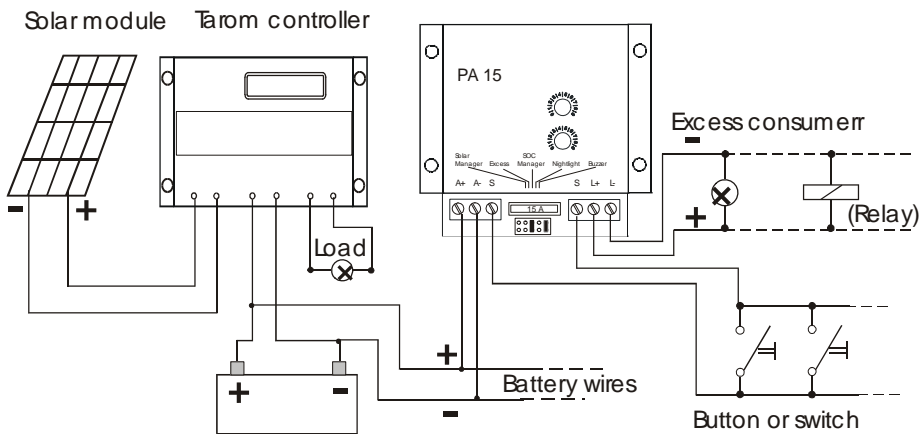

3. To configure the PA15 for this operating mode, plug in the "EXCESS" jumper.

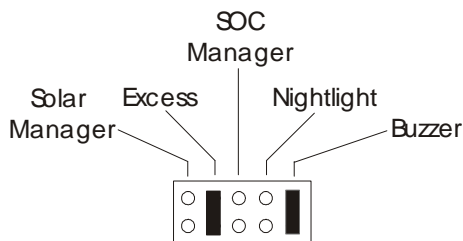

4. Set the adjusting controller “P1” to the position between 0 ... 8. An excess consumer can only be activated, this means it is irrelevant precisely which value between 0 and 8 is set. The “P2” position is also normally ignored in this operating mode. If “P1” is set to position 9, the excess consumer is always active, regardless of the solar system conditions.

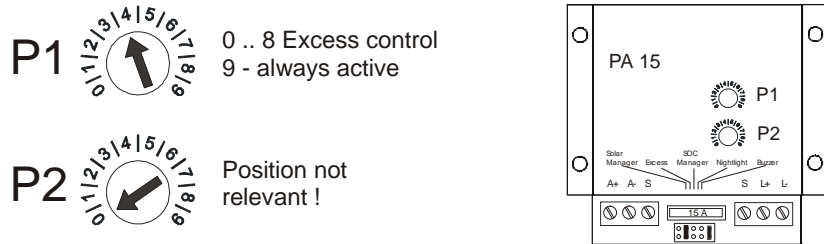

	Identifier	
P 1	Excess = 0	No excess = 9
0 ... 8	ON	OFF
9	ON	ON

4.6.3 Special features, using the button / switch

The connected consumer devices can also be switched on and off using the external button between the S terminals. When the consumer device is shut down by the PA15 and you press the button, the consumer is supplied with power for as long as the button is depressed. If you want to the consumer to be operated permanently in this situation, use a switch (permanent contact) instead of the button (momentary contact).

4.6.4 Safety functions in the event of transmission failure

When commissioning the device, the PA15 output is always shut down first (excess consumer off). Only once a relevant data signal is available to the PA 15 following a successful data transfer is the output active.

If the PA15 has shut off the generator due to its controller position P2 and the data transferred, it can be permanently activated by increasing the identifier to position 9.

If the data transfer is interrupted or not activated in the Tarom, the output remains or becomes shutdown, thus protecting against exhaustive discharge via the excess consumer.

If the data transfer is interrupted, a switch can be used to switch the output (generator) on or off manually. The buzzer does not indicate an interruption in the data transfer.

4.7 Nightlight (NIGHTLIGHT)

4.7.1 What does this mean?

When the TAROM charge controller detects night using the solar modules connected, or no longer detects any solar current, it transmits the night signal to the PA15 TTS remote switch connected. The remote switch(es) connected, which are configured for nightlight functions, will then switch on their load output. When the solar generator supplies current again when daylight breaks, the TAROM stops transmitting the night signal which reactivates the PA15. Multiple lamps can be connected to the load output on a PA15, assuming the max. load current is not exceeded and an automatic nightlight is created using multiple PA15s at different locations in your standalone network.

The Solarix TAROM / POWERTAROM has a few additional settings to control the nightlight function. The corresponding configuration menu in the charge controller can be used to set a delayed start once night has been detected by the Tarom. In addition, the duration of the nightlight function can be restricted.

More information on the precise setting options can be found in the operating and installation instructions for the Solarix TAROM / POWERTAROM.

However, do bear in mind that this creates short delays in switching functions in relation to the night detection feature by the Tarom. The cause of this is related to the transmission security program and provides safe detection and switching.

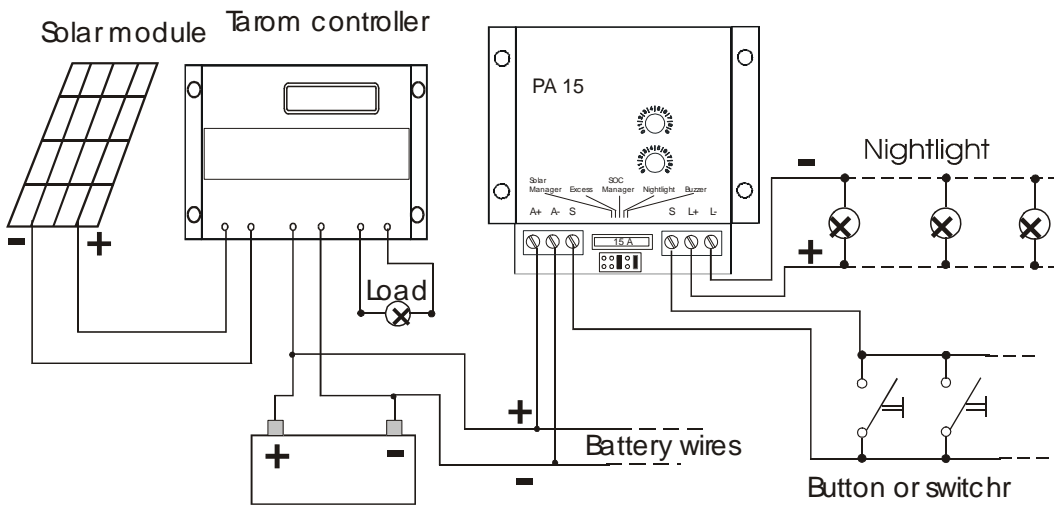

4.7.2 How to do this

1. Connect the PA15 to the battery leads with the correct polarity (A+ / A-).
2. Connect the consumer device (lamp) to the load output (L+ / L-) on the PA15.
3. To configure the PA15 for this operating mode, plug in the "NIGHTLIGHT" jumper.

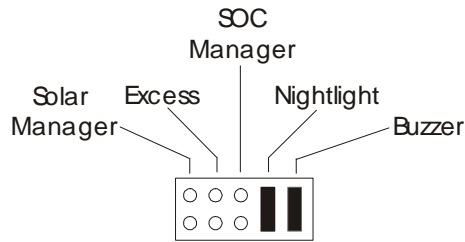

4. No further settings on the PA15 are required. The adjusting controller positions "P1" and "P2" are ignored in this operating mode.

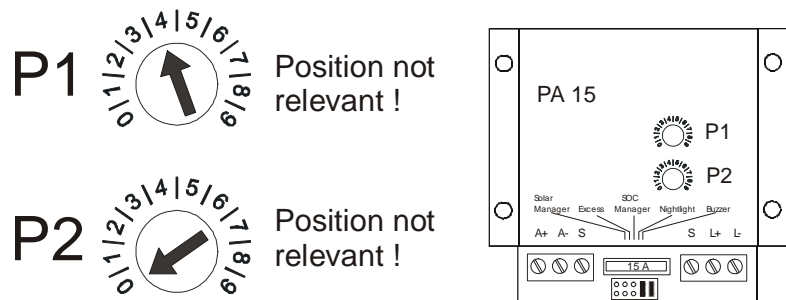

5. In order to set up the time-controlled function, the Solarix Tarom/Powerarom must be programmed accordingly. Please consult the operating manual for the Solarix Tarom for more details.

5 Help with troubleshooting

- **Fuse faulty**

The fuse is not normally triggered without a reason. In this event, please check the device installation before inserting the new fuse. Use only equivalent fuses to replace old ones.

The following reasons can result in a fuse being blown:

- The consumer device or the cabling to the consumer has caused a short-circuit.

Correct the short-circuit and install a new fuse

- The polarity on the battery is reversed or it has been connected to the wrong terminals.

Disconnect the battery and connect with the correct polarity, insert a new fuse.

- The device has been overloaded by excess consumer current.

Reduce the number of consumer devices connected to the PA15, max. 15 A is permissible. Insert a new fuse

- Earth fault

Please observe the instructions given in section 7.7, and the information on earthing in the operating manual for the TAROM/POWERTAROM charge controller.

- Internal short-circuit in the PA15

Disconnect all the consumer devices, insert a new fuse with the battery connected correctly. If the fuse blows again, there is a fault in the device.

- **No function**

Check the connection and the cabling for the Steca PA15.

Check the power supply and the fuse.

Is the PA15 correctly connected to the solar system battery?

If the input voltage in the permissible range of between 10.5V and 60V?

Disconnect all the consumer devices and take out the fuse. Insert the fuse with the battery connected correctly. If an acoustic signal can be heard, the basic function of the device is OK. If the fuse blows, or if there is no acoustic signal despite the correct operating voltage, there is a fault in the device.

Can the consumer device be switched on and off manually using a button / switch between the S terminals?

If so, check the configuration for the relevant function. It may be that there is a problem with the data transfer (see section 7.2.3) or it is not enabled in the TAROM/POWERTAROM (see section 8.2).

If the consumer cannot be switched on manually, there may be a fault in the device.

- **Load output on the PA15 does not switch ON**

Check the basic function of the PA15 according to the instructions in the “**No function**” section.

Check the connection to the consumer as well, along with the correct functioning of the consumer device.

The PA15 does not react immediately to a control signal transmitted. To increase functional safety, the PA15 must receive three identical values, otherwise the safety function for the operating mode selected will be active. Check the behaviour in accordance with section 8 “*Operating modes*”. Please note that a new control signal is only transmitted about once a minute.

- **Load output on the PA15 does not switch OFF**

Check the basic function of the PA15 according to the instructions in the “**No function**” section.

Check the connection to the consumer as well, along with the correct functioning of the consumer device.

The PA15 does not react immediately to a control signal transmitted. To increase functional safety, the PA15 must receive three identical values, otherwise the safety function for the function mode selected will be active. Check the behaviour in accordance with section 8 “*Operating modes*”. Please note that a new control signal is only transmitted about once a minute.

- **PA15 is beeping continuously**

P1 and P2 are set to the same value.

- **No acoustic signal when turning the adjusting controller P1 and P2**

Check the basic function of the PA15 according to the instructions in the “**No function**” section.

A continuous tone will be emitted if both controllers P1 and P2 are set to the same value.

- **PA15 is not receiving any data**

Check the basic function of the PA15 according to the instructions in the “**No function**” section.

The basic requirement is that the battery data transfer in the TAROM/POWERTAROM is activated, see section 8.2

The correct reception of the data can only be checked using suitable measuring equipment (oscilloscope).

It may be that there is interference from other consumers or devices affecting the transmission, see section 7.2.3.

Try to localise the source of interference by shutting down consumer devices.

You can also test by trial and error by connecting the PA15 directly to the battery output terminals on the TAROM/POWERTAROM charge controller. If this improves the reception, it may be that the layout can be optimised.

- **Switch / button function is not working**

Check the basic function of the PA15 according to the instructions in the “**No function**” section.

Also check the switching function of the switch / button itself.

Following the instructions in section 8 “*Operating modes*” to check the extent to which the button function can be used in the operating mode you have selected.

In some operating modes, a distinction is made between a button and a switch function. Please see the instructions for the relevant operating mode for more details.

- **SOC Manager is not working**

Check the basic function of the PA15 according to the instructions in the “**No function**” section.

Compare your settings with the functional description in section 8.4. “SOC Manager”

Please also observe the instructions under point “**PA15 is not receiving any data**”.

- **Generator manager is not working**

Check the basic function of the PA15 according to the instructions in the “**No function**” section.

Compare your settings with the functional description in section 8.5. “Generator manager”

Please also observe the instructions under point “**PA15 is not receiving any data**”.

- **Solar manager is not working**

Check the basic function of the PA15 according to the instructions in the “**No function**” section.

Compare your settings with the functional description in section 8.6. “Solar manager”

Please also observe the instructions under point “**PA15 is not receiving any data**”.

- **Excess manager is not working**

Check the basic function of the PA15 according to the instructions in the “**No function**” section.

Compare your settings with the functional description in section 8.7. “Excess manager”

Please also observe the instructions under point “**PA15 is not receiving any data**”.

- **Nightlight function is not working**

Check the basic function of the PA15 according to the instructions in the “**No function**” section.

Compare your settings with the functional description in section 8.5. “Nightlight function”

Please also see the instructions under point “**PA15 is not receiving any data**” and the instructions on the nightlight function in the TAROM/POWERTAROM charge controller operating manual.

The night detection function on the Tarom can be checked as follows:

- Disconnect all solar modules on the module input for the controller
- Short circuit the module input on the controller

The night detection function can take approx. 5 minutes. Please also bear in mind that the PA15 needs to receive the relevant piece of data three times for safe functioning. Data is transmitted about every minute.

6 Example systems

- Decentralised power management using the SOC Manager
- Control of additional charging units and sources (generators, UPS)
- Solar manager
- Excess consumers
- Nightlight function
- Mixed systems

7 Functional description

Basic function

The PA 15 is a receiver which can only be used in combination with the Solarix Tarom / Powertarom charge controller. The transfer function for sending data to the battery leads must first be enabled on the charge controller; the factory setting is for it to be deactivated.

The activation procedure is described in section 8.2 of this manual.

The PA15 TTS remote switch forms part of the TAROM power management system. It is a data-controlled remote switch for switching consumer devices and generators on and off in a standalone system with DC power supply.

This system allows the user to create a versatile power management system very easily.

The data from the charge controller is transferred on the existing power cable, which means that no additional lines need to be laid for the data signal. This feature permits the system to be installed very easily.

Layout

The device is connected between the battery lead on the solar system and the consumer devices.

The receiver receives the control signals via a signal modulated for the battery lead. The signals modulated using the OOK process (ON-OFF keying) to a 125 kHz carrier are sent with a transfer rate of 300 baud (bit duration 3.33ms). In this process, a new data telegram is sent by the charge controller about once a minute.

The device is primarily a superheterodyne receiver. By generating an intermediate frequency and multiple signal filtering, the receiver achieves a high degree of selectivity and therefore a high level of reception safety.

The data string transferred by the Tarom contains current information at the time of sending for the following:

- Charge status in %
- Identifier for generator control (0 – 9)
- Identifier for excess control (0 or 9)
- Day / night identifier

The remote switch receives the data sent by the charge controller (TAROM), evaluates it and switches its load break switch on or off depending on the device configuration. The load break switch is a low-loss MOSFET with a switching capacity of 15A.

The input voltage may be in the range of between 10.5 V and 60 V. Correct functioning is ensured in a temperature range from -10°C to +50°C.

Product description

The PA15 receiver is used to control additional charge sources, to realise the following:

- The nightlight function on the charge controller
- Programmable, external exhaustive charge protection
- What is known as an excess manager
- Or as a generator manager

The device is configured with a 5-fold jumper block for the operating mode and two adjusting controllers P1 and P2 for the SOC (=state of charge) – values or identifiers for controlling generators or excess consumers.

Only one operating mode can be set at any given time on the jumper block between the two 3-pole connecting terminals. If the overall system is to provide multiple additional functions, additional Steca PA15 units must be used.

An incorrect configuration will NOT be indicated acoustically by the PA15. Please ensure that the jumpers are plugged in correctly and in accordance with the function you require. If an invalid configuration is selected, the load output is shut off by the internal safety function specified internally. If any jumpers are lost, please do not use other materials for connecting the contacts. This could easily cause short-circuits which impair the functioning of the PA15.

The adjusting controller for selecting the switch thresholds or identifiers both have a scale from 0...9.

Assigning the switching thresholds to the SOC value for P1 and P2, for the relevant operating mode:

Value | relevant SOC range | identifier

0:	0 .. 9 % SOC	solar generator / identifier 0
1:	10 .. 19 % SOC	solar generator / identifier 1
2:	20 .. 29 % SOC	solar generator / identifier 2
3:	30 .. 39 % SOC	solar generator / identifier 3
4:	40 .. 49 % SOC	solar generator / identifier 4
5:	50 .. 59 % SOC	solar generator / identifier 5
6:	60 .. 69 % SOC	solar generator / identifier 6
7:	70 .. 79 % SOC	solar generator / identifier 7
8:	80 .. 89 % SOC	solar generator / identifier 8
9:	90 .. 99 % SOC	solar generator / identifier 9

The switching thresholds can be set using the scale. The switching thresholds to be set each represent an SOC value or an identifier. The current SOC value or identifier transferred by the Tarom is compared in the PA15 to the settings on controllers P1 and P2 and a switching function is run in accordance with the operating mode configuration selected.

The procedures for operating the adjusting controllers in the various operating modes can be found in the sections below.

When turning the controller, an acoustic return message will be emitted to facilitate the positioning process. The acoustic signal will always be emitted when changing between two settings. For example, when turning the indicator from position 0 to position 1, the change from 0 to 1 is signalled by a beep.

For example, if you want to change from position 0 to position 6, you will hear six beeps.

If the two controllers are set to the same value, a continuous alarm signal will be sounded as this is a non-permissible state. As a general principle, the shutdown value cannot be the same as the activation value.

The device also permits an external button to be connected. This button has different functions depending on the operating mode. For a more detailed description of the button functions, please see the sections below.

For acoustic signalling, the receiver has a buzzer which provides an audible warning when the load is about to be switched off. This buzzer function is only active in the SOC manager operating mode.

If transmission is possible between Tarom and PA15 or even only partially distorted, specified safety functions will be active which shut down the

consumers connected to the PA15, for example, in order to prevent an exhaustive discharge of the battery.

Depending on the operating mode set on the PA15, the switching threshold values selected on adjusting controllers P1 and P2 and the data transferred by the Tarom, the load output on the PA15 is enabled or blocked.

Enabled in this case means that the battery voltage is available on the PA15 output terminal. The output signal is therefore always related to the system battery.

Blocked means that the connection to the system battery has been interrupted.

As a power MOSFET is used as the switching element, additional charge sources (solar manager) will need to be integrated using an external switching element (relay, contactor). If the additional charge source is connected directly to the load terminals, this charge source cannot be blocked due to the diode integrated into the power MOSFET. This may result in the system battery being overloaded.

The operating modes

The Steca PA15 TTS remote switch has different operating modes. Depending on the function required, the operating mode in question needs to be set on the jumper block and the two adjusting potentiometers. These modes are described below.

Different “fail safe” devices need to be accessed, depending on the operating mode. This device becomes active if no data signal can be received.

SOC control (jumper = SOC MANAGER)

For DC consumer devices

In this case, the remote switch functions as a decentralised exhaustive discharge protection device, i.e. various consumer devices can be switched on and off automatically according to priorities at any installation site.

If the shutdown criterion is fulfilled, the device will emit a warning by beeping for around one minute (or 10 times), before the load is thrown off.

The shutdown threshold is set using controller P1, and the shutdown threshold using P2. Please note that the value set for P1 must always be smaller than the value at P2.

For example, a connected consumer can be switched on at an SOC of $\geq 80\%$ and shut down again when an SOC of 50% is reached.

Safety function:

Without any data received, the consumer should remain switched on. If the PA15 is connected directly to the battery, the battery can be discharged completely.

As an option, the PA15 can also be connected to the load output for the TAROM charge controller. In this case, the last instance of the charge controller (Tarom) exhaustive discharge protection will be the central exhaustive discharge protection.

The transmission safety is also supported by a plausibility check for the data transferred.

By connecting an external button, the consumer can always be switched on and off manually within the operating range set.

Outside this range, the consumer can only be switched on by pressing the button continuously or using a switch.

For DC generators

In principle, the operating mode here is the same as for the consumer.

The activation and shutdown threshold can also be set here.

The jumper setting must not be changed for this operating mode. The only point to ensure here is that the switching threshold is set using P1.

In this operating mode, the value for P1 must always be greater than the value for P2.

For example, the generator is switched on via the load break switch at an SOC of <50% and switched off again at >=50%.

This configuration can be used to control a back-up diesel generator, for example, which is started if the SOC of 50% is not reached.

It is essential that the generator being used cannot exceed the permissible final charge voltage for the battery.

To determine the optimum SOC using the Tarom system manager, an “intelligent shunt” is also required in this case, which allows the charge controller to record this additional charge current.

This shunt is available as an accessory for the Tarom system.

Safety functions:

If there is no data received, the generators connected will be off as the system battery needs to be protected against overloading.

In this operating condition, as well, data security is improved using a plausibility check.

A switch between the S terminals can be used to switch the generator on and off manually, regardless of the control from the PA15.

Solar generator manager (jumper = Solar Manager)

This operating mode is only used for shutting down and activating additional solar arrays – it is not an expansion of the actual charge controller.

The operating mode must be set on the jumper block.

An identifier, in other words the “address” for the device, can be set in the range from 0-8.

This means that up to 8 arrays can be controlled by the charge controller.

For rapid charging of the battery, all the solar arrays connected are enabled in order to utilise all the solar power available.

When the battery reaches its final charge voltage, the charge power is reduced by shutting down the solar arrays in stages to prevent the battery being overloaded.

The additional generators cannot be connected directly to the solar system via the PA15 output. The coupling needs to be created using a suitable switching element (relay, contactor), which in turn can be controlled by the output on the PA15.

In order to prevent reverse current from the battery into the solar generators at night, all arrays are also shut off.

Safety functions:

If there is an error with the data reception (no data received for 3 mins.), the solar generators are shut down as the system battery needs to be protected against overloading.

A plausibility check is used to switch on the generator only once the data signal has been received 3 times. A one-off data reception alone is sufficient as a shutdown command.

A switch between the S terminals can be used to switch the generator connected to the PA15 on and off manually, regardless of the identifier.

Excess manager (jumper = Excess)

This operating mode also needs to be selected on the jumper block.

The excess consumer is activated depending on the current battery voltage. If the final charge voltage has been reached, the excess consumer can be enabled by the PA15. The additional consumer device draws charge power from the battery reducing the voltage on the battery. If a voltage dependent on the active final charge voltage is not reached,

the excess consumer will be shut down once again in order to keep the battery at full charge.

The current which the excess consumer is permitted to pick up to ensure that the battery voltage does not fall below the threshold value, depends on the overall system and needs to be determined experientially.

With changing light incidence in particular, frequent switching on and off of the excess consumer may occur!

Typical excess consumers include: pumps for garden ponds or air conditioning units.

Safety functions:

If no data is received, the excess consumers are switched off as the system battery should not be discharged unnecessarily.

To provide additional data security, the excess message must be received 3 times before an excess consumer is switched on. A one-off reception of the data is sufficient as the shutdown criterion, however.

By connecting an external button, the consumer can always be switched on and off manually during excess operation.

Outside this range, the consumer can only be switched on by pressing the button continuously or using a switch.

Nightlight function

The settings on the receiver are ignored, and the remote switch will only react to the night signal. If “night” is signalled by the controller, the remote switch will be activated.

Safety functions:

If no data is received, the lamps connected are switched off as the system battery should not be discharged unnecessarily (during the day).

The nightlight message must be received 3 times before the consumer is switched on or off.

By connecting an external button, the consumer can always be switched on and off manually during nightlight operation.

If there is no nightlight signal, the consumer can only be switched on by pressing the button continuously or using a switch.

Block diagram

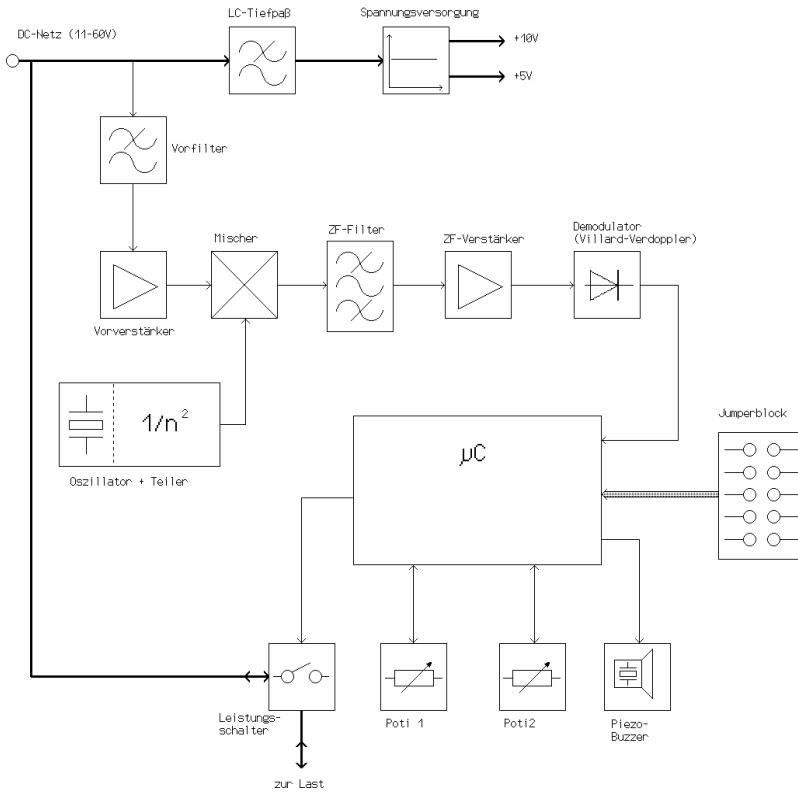

8 Technical data

Operating voltage range:	10.5V.. 60 V
Intrinsic consumption:	< 5 mA
Maximum continuous current:	15 A @ 25°C ; 10 A @ 40°C
Maximum one-off pulse current:	100 A, possible pulse duration determined by the fuse used; max. < 10us
Overcurrent protection:	15 A flat fuse
Reverse polarity protection:	Reverse polarity protection diode + fuse
Receiver:	Superhet principle
Data rate:	300 Bd
Signal frequency:	125 kHz
Intermediate frequency:	450 kHz
Operating temperature range:	-10 .. +50°C
Protection classification:	IP22

9 Miscellaneous



703639